

Parts for Motor Case

No.	Name of Parts	Per Set	Parts No.
M	Motor Case Assy.	1set	0377 0011 04 99
※1	M1 Motor Case (A)	1	0377 0011 01 01
※1	M2 Motor Case (B)	1	0377 0011 01 02
M3	Hexagon Socket Bolt (M3×28)	2	8070 3155 00 00
M4	Hexagon Socket Bolt (M3×12)	5	8070 3113 00 00
M5	Hexagon Socket Bolt (M3×10)	1	8070 3062 00 00
M6	Hexagon Nut (M3)	8	9500 1041 00 00
M7	Bushing (A)	1	0368 0728 00 01
M8	Hexagon Nut (M4)	2	9500 1034 00 01
M9	Lamp Holder (A)	2	0368 0959 00 01
M10	Lamp Holder (B)	2	0368 0959 00 02
M11	Buzzer Cover	1	0368 0348 00 00
M12	Buzzer Assy.	1set	0181 0903 02 99
M13	Cover Plate (A)	1	0368 0014 00 01
M14	Lamp Circuit Board Assy.	1set	0368 0351 00 99
M15	Fan (A) Assy.	1set	0368 1556 00 99
M16	Screw (M3×35)	4	9410 2049 00 00
M17	Rubber Packing	1	0378 0359 00 00
M18	Motor Assy.	1set	0368 0330 02 99
M19	Cable (A) Assy.	1set	0368 0902 02 99
M20	Frame Ground Plate (A) Assy.	1set	0368 1575 01 99
M21	Frame Ground Plate (C)	1	0368 1575 00 03
M22	Screw (M3×8)	1	9410 2052 00 00
M23	Screw (M3×5)	4	9410 2044 00 00
M24	Insulating Sheet	1	0368 1525 00 01
M25	Tool Circuit Board	1	0368 1524 02 00
M26	Screw (M3×8)	2	9540 1017 00 00
M27	Throttle Assy.	1set	0368 0186 01 99
M28	Binding Band	5	9790 1008 00 00
☆ 1	ST-Packing (15.2×20×0.1)	1	8011 1039 00 00
☆ 2	ST-Packing (15.2×20×0.2)	1	8011 1021 00 00
☆ 3	ST-Packing (15.2×20×0.3)	1	8011 1022 00 00
☆ 4	ST-Packing (15.2×20×0.4)	1	8011 1140 00 00
☆ 5	ST-Packing (15.2×20×0.5)	1	8011 1141 00 00
6	Wave Washer (1410201-41014)	1	8042 6001 00 00
7	Washer (15.1×19×2)	1	8040 1175 00 00

☆marked parts ; one of them is used.

※1 Please replace the Motor Case(A) and the Motor Case(B) as a unit.

No.	Name of Parts	Per Set	Parts No.
Parts for e-M700-V			
MV	Motor Case Assy. (Rear Cable)	1set	0377 0011 04 98
M23'	Screw (M3×8)	5	9410 2044 00 00
M29	O-Ring (0.8×22×23.6)	1	9010 6040 00 00
M30	Buzzer Holder	1	0368 0333 01 00
M31	Cover Plate (C)	1	0368 0014 00 03
M32	Screw (M3×8)	4	9440 2029 00 00
M19V	Cable (B) Assy. (Rear 2m)	1set	0368 0902 02 98
M33	Harness	1	0368 0208 00 00
M34	Screw (M3×5)	2	9410 2044 00 00
Parts for e-M700-S			
MS	Motor Case Assy. (Short Cable)	1set	0377 0011 04 97
M19S	Cable (C) Assy. (0.3m)	1set	0368 0902 02 97
Parts for e-M700-SV			
MSV	Motor Case Assy. (Rear Short Cable)	1set	0377 0011 04 96
M23'	Screw (M3×8)	5	9410 2044 00 00
M29	O-Ring (0.8×22×23.6)	1	9010 6040 00 00
M30	Buzzer Holder	1	0368 0333 01 00
M31	Cover Plate (C)	1	0368 0014 00 03
M32	Screw (M3×8)	4	9440 2029 00 00
M19SV	Cable (D) Assy. (Rear 0.3m)	1set	0368 0902 02 96
M33	Harness	1	0368 0208 00 00
M34	Screw (M3×5)	2	9410 2044 00 00
Standard Accessories of -V Type			
	Hanger(C)CP	1set	0368 0017 00 97
	Hanger(C)CP1	1set	0368 0017 00 69
	Hanger(C)	1	0368 0017 00 03
	Hanger Ring	1	0217 0018 00 00
	Bushing(C)	2	0368 0728 00 03
	Hexagon Socket Bolt (M4×18)	4	8070 3095 00 00
	Spring Washer (M4)	4	9200 1004 00 00
17'	Protector(B)	1	0368 0029 00 02
Optional Accessories			
18	Hanger (A) Assy.	1set	0368 0017 00 99
	(a) Hanger (A)	1	0368 0017 00 01
	(b) Hexagon Socket Bolt (M4×12)	2	8070 3059 00 00
	(c) Spring Washer (M4)	2	9200 1004 00 00
19	Hanger (B) Assy.	1set	0368 0017 01 98
	(a) Hanger (B)	1	0368 0017 00 02
	(b) Bushing (B)	2	0368 0728 01 02
	(c) Hexagon Socket Bolt (M4×20×16)	2	8070 3010 00 00
	(d) Spring Washer (M4)	2	9200 1004 00 00

YOKOTA

Electric system wrench with built-in angle sensor

MODELS (YES.No.)	TOOL No.	MODELS (YES.No.)	TOOL No.
e-M700 (04)	0377 0000 0400	e-M700-S (04)	0377 0000 0421
e-M700-V (04)	0377 0000 0416	e-M700-SV (04)	0377 0000 0422

Exploded View of Motor Case

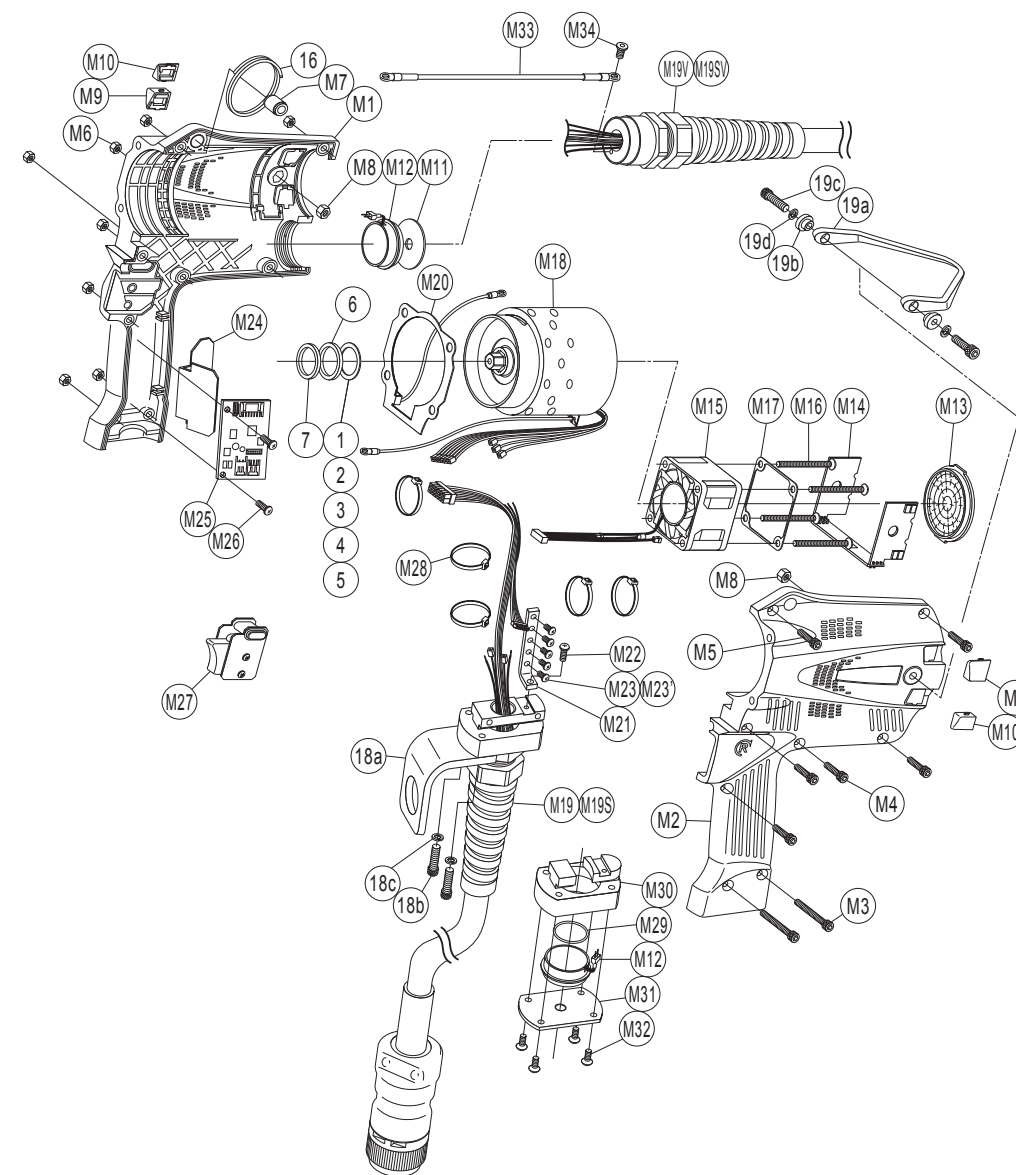

YOKOTA INDUSTRIAL CO.,LTD.

Electric system wrench with built-in angle sensor

Parts for Liner Case

No.	Name of Parts	Per Set	Parts No.
L	Liner Case Assy.	1set	0377 0422 00 99
L1	Liner Case	1	0377 0422 00 00
L2	O-Ring (1.78×29.87×33.43)	1	9011 2003 00 00
L3	Liner Cap	1	0186 0423 00 00
L4	Liner Upper Plate	1	0377 0424 00 00
L5	O-Ring (1.78×26.7×30.26)	1	9011 6064 00 00
L6	Liner Assy.	1set	0389 0425 00 99
	(a) Liner	1	※ ↑
	(b) Pin FF (2×4.8)	2	8052 1041 00 00
	(c) Pin FF (2×7.8)	2	8052 1029 00 00
L7	Relief Valve	1	0377 0245 00 00
L8	Pin (1.5×4)	1	8051 1314 00 00
L9	Liner Shaft	1	0377 0796 00 00
L10	Blade	2	0351 0719 00 00
L11	Spring (3.1×20)	2	8020 1296 00 00
L12	Liner Lower Plate (A)	1	0371 0426 00 01
L13	Liner Lower Plate (B) Assy.	1set	0377 0426 00 99
	(a) Liner Lower Plate (B)	1	※ ↑
	(b) Pin (3×5)	1	8052 1031 00 00
L14	Adjust Bolt	1	0377 0522 00 00
L15	O-Ring (N2)	2	9010 4001 00 00
L16	Back-up Ring (N2)	1	9090 2001 00 00
L17	Oil Plug	2	0181 0010 00 00
L18	O-Ring (N2)	2	9010 4001 00 00
L19	Spring (1.9×2.5)	1	8020 1365 00 00
L20	Ball (2mm)	1	9150 1001 00 00
L21	O-Ring (P12)	1	9011 7001 00 00
L22	Back-up Ring (12×16×0.8)	1	9090 1010 00 00
☆ 1	ST-Packing (15.2×20×0.1)	1	8011 1039 00 00
☆ 2	ST-Packing (15.2×20×0.2)	1	8011 1021 00 00
☆ 3	ST-Packing (15.2×20×0.3)	1	8011 1022 00 00
☆ 4	ST-Packing (15.2×20×0.4)	1	8011 1140 00 00
☆ 5	ST-Packing (15.2×20×0.5)	1	8011 1141 00 00
8	Upper Plate Spacer	1	0377 0301 00 00
9	Ball Bearing (6802ZZ)	1	9100 5037 00 00
10	Pin FF (2×4.8)	1	8051 1037 00 00
11	Lower Plate Spacer	1	0368 0311 00 00
12	Ball Bearing (6702)	1	9100 1079 00 00
13	Pin (7.5×12.7)	1	8051 1330 00 00

The part "※" can not be supplied individually.
So please order it as a unit of assembly shown by
arrow mark (↑).

☆marked parts ; one of them is used.

MODELS (YES.No.)	TOOL No.	MODELS (YES.No.)	TOOL No.
e-M700 (04)	0377 0000 0400	e-M700-S (04)	0377 0000 0421
e-M700-V (04)	0377 0000 0416	e-M700-SV (04)	0377 0000 0422

Exploded View of Liner Case and Hammer Case

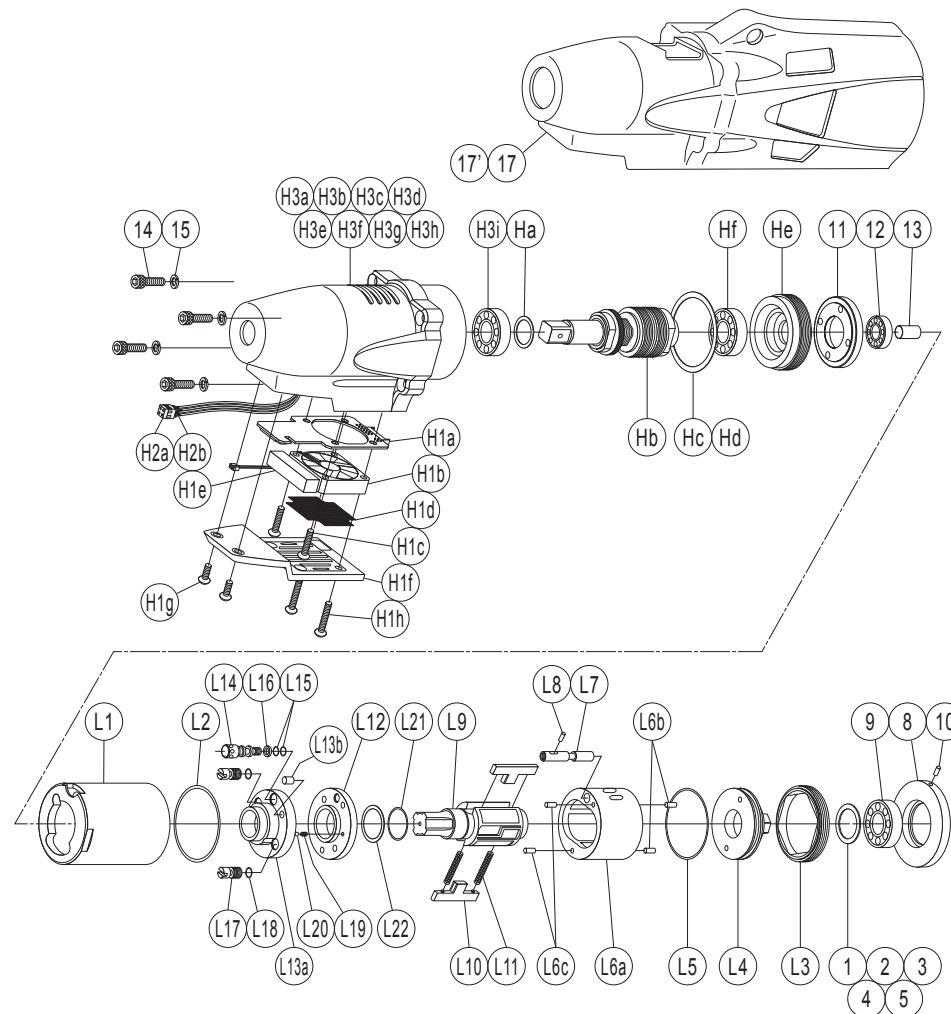

Parts for Hammer Case

No.	Name of Parts	Per Set	Parts No.
H	Hammer Case Assy.	1set	0377 0401 00 99
H1	Hammer Case (1) Assy.	1set	0368 0401 00 69
H2	Hammer Case (2) Assy.	1set	0368 0401 00 68
H3	Hammer Case (3) Assy.	1set	0368 0401 00 67
	(a) Hammer Case	1	※ ↑
	(b) Core (A) Assy.	1set	※ ↑
	(c) Core (C)	2	※ ↑
	(d) Spacer (A)	1	※ ↑
	(e) Core (D) Assy.	1set	※ ↑
	(f) Set Screw (M4×5)	1	※ ↑
	(g) Sensor Base	1	※ ↑
	(h) MR Sensor Circuit Board Assy.	1set	※ ↑
	(i) Ball Bearing (6801ZZ)	1	9100 5028 00 00
	(a) Housing (DF11-4DS-2C)	1	8470 4004 00 00
	(b) Contact (DF11-2428SC)	4	8480 2001 00 00
	(a) Printed Circuit Board Assy. (Angle)	1set	※ ↑
	(b) Fan (B) Assy.	1set	0368 1556 00 98
※2	(c) Screw (M3×15)	2	9410 2047 00 00
	(d) Mesh Cover (B)	1	0368 1604 00 02
	(e) Dust Cover	1	0368 1193 00 00
※2	(f) Cover Plate (B)	1	0368 0014 00 02
	(g) Screw (M3×8)	2	9440 2029 00 00
	(h) Screw (M3×18)	2	9440 2030 00 00
★	(a) ST-Packing (12.5×16×0.3)	1	8011 1012 00 00
	(b) Main Shaft Assy.	1set	0377 0614 01 99
☆	(c) C-Packing (30.5×35×0.1)	1	8010 1297 00 00
☆	(d) C-Packing (30.5×35×0.2)	1	8010 1143 00 00
	(e) Bearing Case	1	0368 0650 00 00
	(f) Ball Bearing (6802ZZ)	1	9100 5037 00 00
14	Hexagon Socket Bolt (M4×12)	4	8070 3059 00 00
15	Spring Washer (M4)	4	9200 3012 00 00
Standard Accessories			
16	Hanger Ring	1	0217 0018 00 00
17	Protector(A)	1	0368 0029 00 01

The part "※" can not be supplied individually.
So please order it as a unit of assembly shown by
arrow mark (↑).

★Marked parts may not be used, in some case.

☆marked parts ; one of them is used.

※2 Please replace the Mesh Cover(B) and the Cover Plate(B) as
a unit.